

# MODEL SELECTION & ORDERING

## Multi-energy selection

1. Please refer to P15 for the details of all kinds of heat sources and corresponding chiller models.
2. If customer chooses solar energy to be heat source, fuel (natural gas or light oil) can be used at night time and in cloudy or raining days, instead of investing a lot on larger solar collector and thermal storage equipment. Thus the investment on solar collector system can be paid back within 3 to 5 years.
3. If customer has existing industrial waste equipment or power generator, the exhaust from them can be utilized. For a new air conditioning system, cogeneration system should be considered to utilize the exhaust in order to reduce energy cost. As the power generation and air conditioning are not needed simultaneously all the time, a back-up heat source (natural gas or light oil) is required for independent operation. The extra investment on utilization of waste heat will be paid back within 3 to 5 years.
4. The optional fuels include natural gas, coal gas and light oil (diesel oil, naphtha and kerosene), the dual fuel type can also be chosen.
5. The products listed in this brochure cover all the heat sources applicable to absorption chiller/heater and every application mode, including a chiller powered by 2 or 3 heat sources.

## Heat source selection

Saturated steam pressure should be indicated for a steam chiller. Note: 0.6MPa, 0.7MPa, and 0.8MPa are the standard pressure. But the prices of 0.7MPa and 0.8MPa chillers are lower.  
Heat source W. inlet temp. and flowrate (or temp. difference), etc. should be indicated for a hot water chiller.  
Please pay attention to changes of steam pressure, heat source W. temp. and flowrate, which will affect the chiller's capacity and COP.  
Exhaust data, such as temp., flowrate and composition, etc. should be indicated for an exhausted chiller.  
Notice: The higher heat source temp., the higher COP and the lower price as well.

## Temp. selection

The higher the chilled W. outlet temp., or the lower the cooling W. inlet temp., or the higher the heat source temp., the higher cooling capacity and COP. Please pay best attention to Performance Curves, which seems complicated but actually is easy to consult. The effect of ambient conditions on cooling capacity and COP can be calculated in 2 minutes. It is a unique mode of BROAD which is both precise and convenient. Concerning the choice of the chilled W. temp., please refer to "How to decide the flowrate".

## Flowrate selection

Flowrate requirements must be carefully studied. A large temp. difference and low flowrate can be a good solution to reduce the power consumption of water pumps and investment in pipeline network. To the users with large pipeline radius (for instance district cooling & heating system), low flowrate is of the most importance to raise investment payback ratio and save energy. So besides the chilled W. temp. shown in the performance data, BROAD recommends chilled W. inlet/outlet temp. differences 8°C, 9°C, 10°C or even 15°C. BROAD can design the water passes specially to meet customer's temp. difference requirement without affecting cooling capacity and COP due to the low flowrate. An example of big temp. difference is as follows:

District cooling	5°C/15°C or 6°C/15°C	heating	75°C/57°C
Small radius air conditioning:	cooling 6°C/14°C or 7°C/14°C	heating	70°C/57°C

Cooling W. flowrate (a) of BROAD absorption chillers is 30% less than that of traditional chiller. Designer can choose cooling tower of one size larger (the same size required for the high flowrate option) per performance curves. Thus the cooling W. pump size and electrical consumption can be reduced dramatically without increasing size of cooling tower.  
Due to lower flowrate and less water resistance, BROAD chillers are 20%~50% electricity saving for water pumps compared with other chillers. Special attention must be paid for pump model selection.

## Model selection

If the customers have already decided the load, heat source, chilled W. temp. and cooling W. temp., then they can select the chiller model by marking on the performance curves with color pencil, or the customers can also send the data to BROAD for model selection.

## Quantity selection

To decide the quantity to be used, you should take load, load distribution, building function, installation site and economic factors into consideration. Please be noted that the fewer units, the lower initial investment and operation cost (as the chiller's COP will be higher and water system's electric consumption will be lower at part load). You need not consider having back-up units because continuous operation is better for the life-span than intermittent operation. 1~2 units are recommended for small and medium sized application and 3 units for big-sized application (at least 2 units are to be selected for continuous operation all year round). BROAD can manufacture the biggest chiller in the world, which enables customers to select fewer units, and all the main shells are shipped as a single-piece delivery which is easy for installation.

## Pressure requirement

The rated pressure limit is 0.8MPa for chilled/heating W. and cooling W., 0.81~1.2MPa for high-building type, 3 categories: 1.21~1.6MPa, 1.61~2.0MPa, 2.01~2.4MPa for extra high-building type.  
Please calculate the pressure of cooling W. system and chilled/heating W. system separately and specify the information in your order. If system pressure is over 0.8MPa, you can choose high-building type chiller, but we do not easily recommend extra high-building chiller. A solution is to divide the system into several sections instead of choosing high-building type chiller. In this way, you may save the extra cost of initial investment, piping and maintenance cost of a high-building chiller.

## Dimension

If limited by access of customers' machine room (or limited by container transportation), you can choose split shipment. The chiller normally will be divided into two pieces as Main Shell and HTG. BROAD technicians will connect 3 pipes at the jobsite. Customers need to prepare welding equipment, nitrogen and provide cooperation.

## Control mode

The standard model is equipped with complete automatic control system as well as remote control through internet. Please refer to the P&I diagram for details.  
If a building automation system (BAS) has been used, the BAS control interface should be selected optionally. If the BAS interface is not ordered along with the chiller, it can be purchased later.

## Contract

The 9 elements above mentioned should be made sure and clarified in the contract when placing an order. Meanwhile, the model type should be written out strictly according to the "nomenclature". Any negligence might lead to delivery mistakes beyond remedy.  
The delivery date is generally 6 months, but for oversized model or special-ordered model, it is 7~9 months. If the specific date can not be decided upon signing the contract, it can be specified 2 months before the contract delivery date by filling in "Delivery Confirmation".  
For technically-complicated model, there must be a "Technical Confirmation" as the attachment of the contract.



# HOW TO CHOOSE ENERGY SOURCE FOR AIR CONDITIONING

## Example : various kinds of energy-saving systems

Type 1. System matched with turbine generator (BE series)

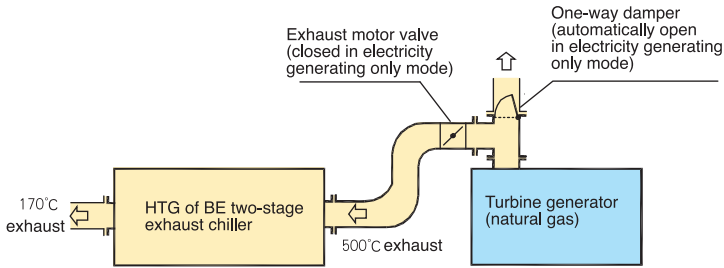

Type 2. System matched with mini-turbine generator(BDE series)

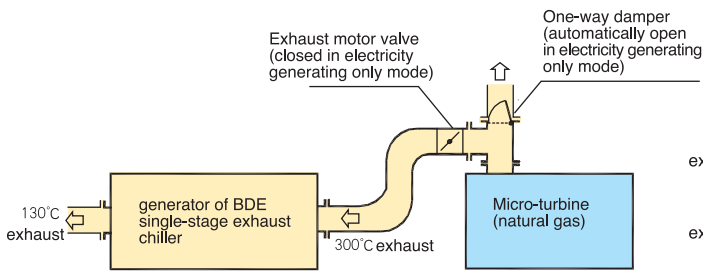

Energy saving is always a topic for the mankind. It benefits the environment, the national economy as well as the customers' investment. The air conditioning energy consumption costs most in buildings' operation, whereas the selection of proper energy source and the matching air conditioning equipment are the key factors in building investment. BROAD proposals of energy and air conditioners here are based on the experience from European and American customers, which are very edgy-cutting and practical—high investment payback ratio, mature equipment & system technology.

Type 3. System matched with turbine generator (BZE series)

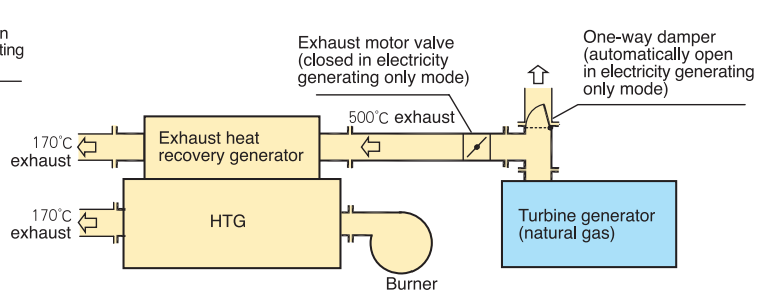

Type 4. System matched with internal combustion engine (BZHE series)

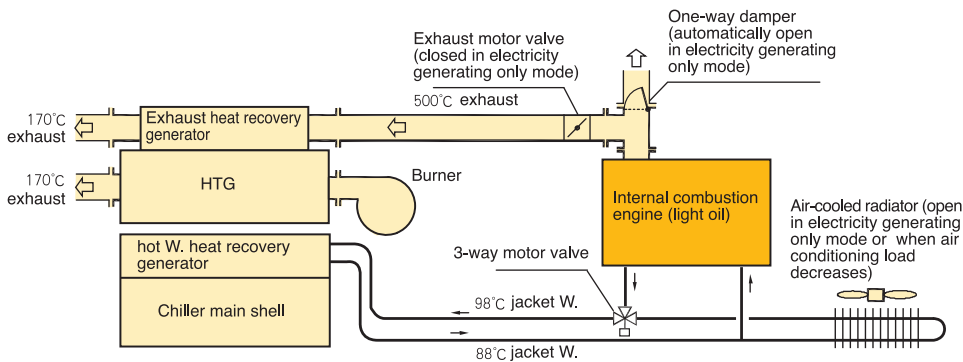

Type 5. System matched with micro-turbine (BZ series)

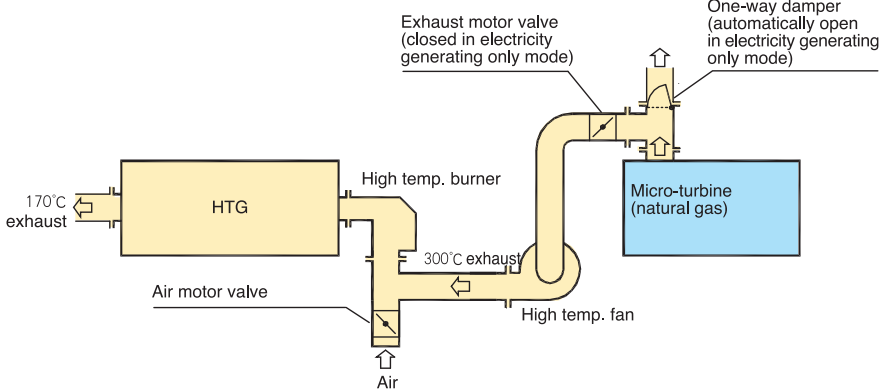

Type 6. System matched with parabolic trough solar collector (BZS or BZH series)

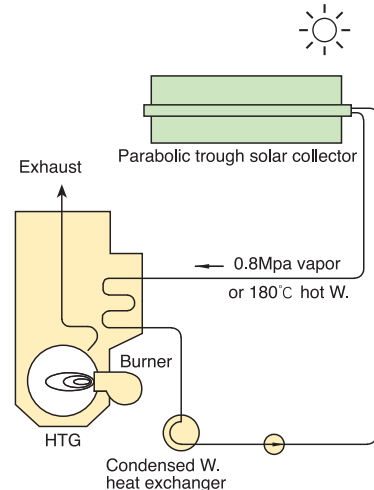

Type 7. System matched with garbage incinerator (BS or BDE series)

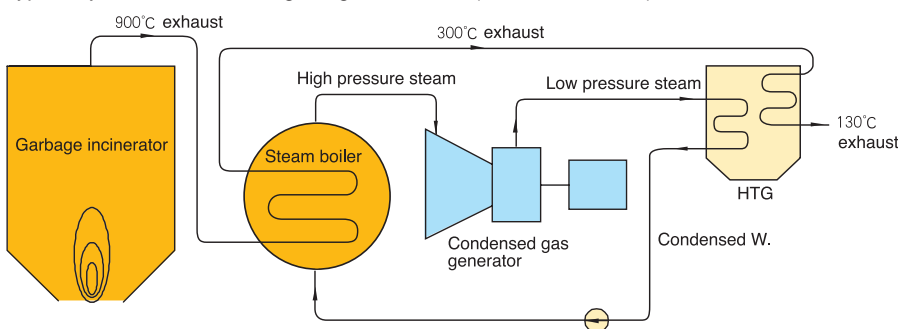

# MODEL SELECTION OF ENERGY-SAVING SYSTEM

Type	Objective	Primary Energy	Facilities Matching	Operation Mode & Function	Main Advantages	Disadvantages & Limitations	Energy Efficiency	Investment Factor
1	vast energy-saving (applicable to large building block or district cooling/heating system)	natural gas	1.turbine 2.two-stage exhaust chiller/heater( BE series)	· the generator supplies electricity to buildings or grid · chiller/heater provides cooling/heating utilizing exhaust from power generating	no energy input needed for cooling/heating	power generating and cooling must be simultaneous; if only electricity is needed, the exhaust will not be utilized; if electricity is not needed, there is no energy input.	power generation about 33%, cooling about 64% (exhaust volume 67% X utilization ratio 0.7 XCOP137%=64%)	3
2	power generation and cooling in small scale (<100kW)	natural gas	1.micro-turbine 2.single-stage exhaust chiller/heater( BDE series)	· the generator supplies electricity to buildings or grid · chiller/heater provides cooling/heating utilizing exhaust from power generating	no energy input needed for cooling/heating	power generating and cooling must be simultaneous; if only electricity is needed, the exhaust will not be utilized; if electricity is not needed, there is no energy input.	power generation about 30%, cooling about 34% (exhaust volume 70% X utilization ratio 0.63 X COP78% =34%)	2.7
3	vast energy-saving & supplying electricity or cooling/heating independently (applicable to large building block or district cooling/heating system)	natural gas	1.turbine 2.direct-fired & exhaust type ( BZE series)	· the generator supplies electricity to buildings or grid · chiller/heater provides cooling/heating utilizing exhaust from power generating · if the generator is off, natural gas can be used for cooling/heating.	No energy input is needed for cooling/heating during power generating, cooling/heating can be provided during less power generating or no power generating.	high investment and high maintenance cost	about 30% for power generation, about 64% for cooling (for cooling only mode 131%)	3.5
4	areas without natural gas, vast energy-saving	light oil (diesel, kerosene and naphtha)	1.internal combustion engine 2.direct-fired & exhaust and hot water type (BZHE series)	· the generator supplies electricity to buildings and grid; · exhaust/ jacket water for cooling/heating ; · if the generator is off, light oil can be used for cooling/heating.	no energy input is needed for cooling/heating	generator is very noisy and much vibrative; much maintenance needed; short life-span for generator; the exhaust is not as clean as the natural gas.	about 36% for power generation, about 54% for cooling (for cooling only mode 131%)	2.5
5	power supply for chiller and water system, energy-saving and low investment.	natural gas (or light oil)	1.micro-turbine 2.DFA (with high-temp. burner) (BZ series)	the generator provides electricity for chiller/heater, cooling water pump, chilled/heating water pump, cooling tower, etc. ( DFA uses exhaust to replace combustion air, i.e. reburning).	low investment; 100% utilization of the exhaust from the generator.	small capacity for electricity supplying, unable to cover other parts of buildings.	cooling 147% heating 102%	1.3
6	max. energy-saving and environmental friendly(applicable to all kinds of buildings, from villa to district cooling/heating system)	solar energy; supplementary natural gas (or light oil)	1.parabolic trough solar collector 2.direct-fired & steam type or direct-fired & hot water type (BZS series or BZH series)	· solar collector produces 0.8 MPa steam (or 180°C hot water); · the chiller makes use of solar energy for cooling on sunny days. Natural gas will be used on rainy days and at night.	low operation cost, most environmental friendly (house or parking lot can be built under the space-taking solar collector)	solar collector occupies large spaces; not efficient in places with short sunshine period or heavy air pollution; high investment.	no fuel input needed for cooling on sunny days;cooling by fuel on rainy days and at night: 131% for cooling and 91% for heating	1.7-3
7	energy-saving by making use of urban garbage (applicable to district cooling/heating system)	garbage	1.garbage incinerator 2.steam boiler 3.steamer generator 4.steam chiller (BS series)	· high pressure steam produced by burning garbage supplies the power to steamer generator. · the chiller heats LiBr with low pressure steam from steamer generator (acting the function of generator condenser as well)	no fuel input is needed for cooling, reducing investment on generator condenser	subject to the amount of garbage	power steam 137%	0.8 power generation from garbage burning not included
8	meeting large heating and small cooling capacity requirement, energy-saving.	natural gas	1.turbine 2.heat recovery boiler 3.two-stage steam chiller (BS series or two-stage hot water BH series)	· the generator supplies electricity to buildings and grid; · heat recovery boiler can turn exhaust into steam or hot water; · steam or hot water is utilized for cooling; · heat recovery boiler can provide heating independently	For customers with large heating requirement, investment in heating facilities can be saved; heat recovery boiler can provide heat independently, with simple management.	complicated facilities and high investment	steam cooling 137%	3.8-4.8
9	high steam demand and low cooling demand.	natural gas (light oil or clean coal)	1.steam boiler 2.steam chiller (BS series or BDS series)	steam used for cooling	low investment; simple system	subject to steam supply.	two-stage cooling 137% single-stage cooling 78% (excluding boiler efficiency)	0.8 excluding boiler
10	using existing urban heating system	(heating system)	steam type or hot water type chiller (BS/BDS series or BH/BDH series)	steam (or hot water) used for cooling	low investment, simple system	subject to steam supply.	two-stage cooling 137% single-stage cooling 78%	0.8 excluding heating system
11	low investment; max. flexibility	natural gas (light oil)	DFA (BZ series, refers also to specific brochure)	natural gas (light oil) for cooling/ heating	low investment; simple system; great flexibility	can not use the exhaust and solar energy	cooling 131% heating 91%	1

Notes: 1. The investment factor indicates the investment proportion of each type of project. Data in the above sheet is calculated basing upon DFA (direct-fired type LiBr absorption chiller/heater) with the corresponding cooling tower, cooling W. pump and chilled/heating W. pump.

2. The low pressure exhaust from condensed gas power stations (coal, oil and gas) can be used for cooling, the methods and effects are similar to those of garbage power station (type 7).

3. The exhaust from turbine can be used not only for air conditioning but also for cooling the turbine inlet air, which can improve power generation efficiency (type 1, 3 & 8).

4. We hope the readers can pay best attention to this page! District air conditioning and distributed energy system (small urban power station+heat recovery) are the directions of future urban energy development. The heat recovery absorption chiller which can utilize all kinds of waste heat will be the only choice, while cooling and energy will be the definite choice of mankind to the zero-pollution energy era.



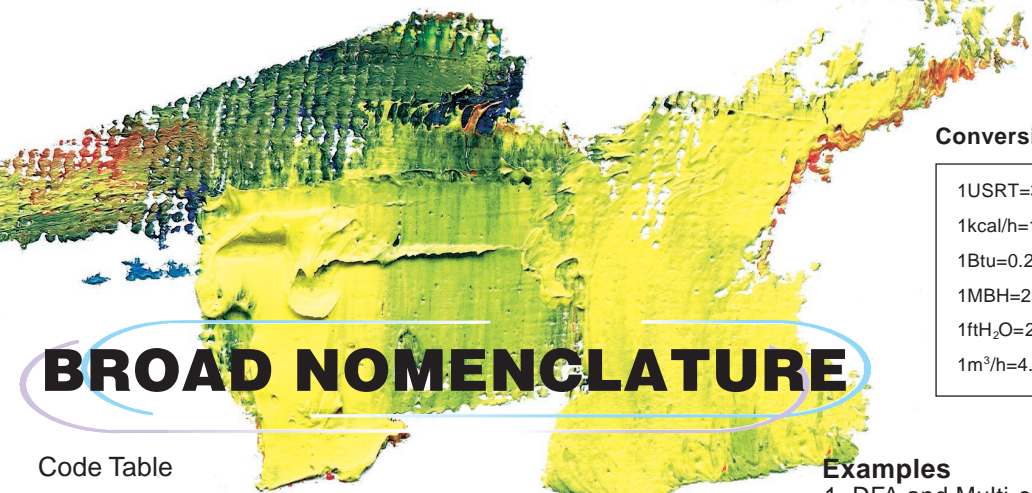

# BROAD NOMENCLATURE

## Conversion Table

1USRT=3.517kW	1USGal=3.785L
1kcal/h=1.163W	1MPa=6.895psig
1Btu=0.252kcal	1bar=0.1MPa
1MBH=252kcal/h	1klbs=454kg
1ftH <sub>2</sub> O=2.989kPa	1m <sup>3</sup> =35.3 ft <sup>3</sup>
1m <sup>3</sup> /h=4.4GPM	°F=(°C×1.8)+32

## Code Table

Code	Type	Notes
Product	BZ	direct-fired absorption chiller/heater gas,oil
	BS	two-stage steam chiller steam pressure 0.3~0.9MPa
	BDS	single-stage steam chiller steam pressure ≤ 0.2MPa
	BH	two-stage hot water chiller heat source water temp. 140~200°C
	BDH	single-stage hot water chiller heat source water temp. 75~120°C
	BE	two-stage exhaust chiller/heater exhaust inlet temp. ≥ 400°C
	BD	single-stage exhaust chiller/heater exhaust inlet temp.230~350°C
	BZS	direct-fired & steam chiller gas/oil and 0.3~0.9MPa steam
	BZH	direct-fired & hot W. chiller gas/oil and 140~200°C hot water
	BZE	direct-fired & exhaust chiller gas/oil and ≥ 400°C exhaust
BZHE	direct-fired & exhaust & hot W. chiller gas/ oil, 90~120°C hot water and ≥ 400°C exhaust	
BZY	BROAD outdoor package DFA steam type, hot water type exhaust type also available	
BCT	BROAD house gas air con gas/ oil	
Energy	B	light oil (diesel, kerosene, etc.) heating value 9700~11000kcal/kg (17446~19704Btu/lb)
	C	high heating value gas(LPG,etc.) heating value 18000~25000kcal/Nm <sup>3</sup> (2022~2809Btu/ft <sup>3</sup> )
	D	medium heating value gas (natural gas,etc.) heating value 7000~12000kcal/Nm <sup>3</sup> (787~1348Btu/ft <sup>3</sup> )
	E	low heating value gas (town gas,etc.) heating value 3000~5000kcal/Nm <sup>3</sup> (337~562Btu/ft <sup>3</sup> )
	0.3~0.9	steam inlet pressure MPa two-stage
	0.01~0.2	steam inlet pressure MPa single-stage
	140~200	heat source water temp. °C two-stage
	75~120	heat source water temp. °C single-stage
400~600	high temp. exhaust inlet temp. °C two-stage	
230~350	low temp. exhaust inlet temp. °C single-stage	
Function	k	cooling-heating type omitted for cooling-heating-hot water type
	k <sub>2</sub>	simultaneous cooling-heating operation (4-pipe system)
	d	cooling-only type
	w	cooling-hot water type
Heating capacity	H1	HTG enlarged H1 20% more heating capacity
	H2	HTG enlarged H2 40% more heating capacity
	H3	HTG enlarged H3 60% more heating capacity
	H4	HTG enlarged H4 80% more heating capacity
Water temp.	18~40	cooling W. temp. °C if the water temp. is the rated data in the catalogue, it will not be indicated in the nomenclature
	3~17	chilled W. temp. °C
Power	A1	single-phase 220V 50Hz China, Europe, India, Iran, etc.
	A2	single-phase 110V 50Hz Japan, Brazil, Columbia, etc.
	A3	single-phase 220V 60Hz Saudi Arabia, Brazil, Mexico, Peru, etc.
	A4	single-phase 110V 60Hz U.S., Japan, Canada, Cuba, etc.
	B1	three-phase 380V 50Hz China, Europe, India, Iran, etc.
	B2	three-phase 415V 50Hz Malaysia,Singapore,Australia,etc.
	B3	three-phase 460V 60Hz U.S., Brazil, Honduras, etc.
B4	three-phase 220V 60Hz U.S., Japan, Canada, Cuba, etc	

- Note: 1. For those heat source ranges not specified in the energy item, whether to use single-stage or two-stage chiller should be decided per chilled water and cooling water temperature.
2. In the nomenclature, the energy code should be specified; the chilled water and cooling water temperature can be omitted if they are the rated data in the catalogue;the model code can be omitted if it is the same as the cooling capacity.
3. The default power code is A1 for BCT16, BCT23, indoor units and hot water tanks, and B1 for all others.
4. Chiller with chilled/cooling W. pressure limit above 0.8MPa is considered high building type. Introduce code "F" for chilled W. and code "M" for cooling W.,then:Fa/Ma indicates >0.8MPa type; Fb/Mb indicates >1.2MPa type; Fc/Mc indicates >1.6MPa type; Fd/Md indicates 2~2.4MPa type.

## Examples

### 1. DFA and Multi-energy DFA

Example 1 (DFA standard)

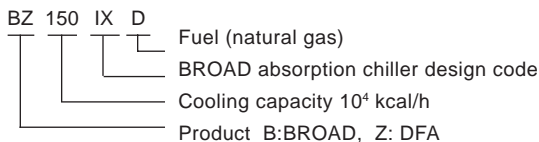

Example 2 (DFA special):

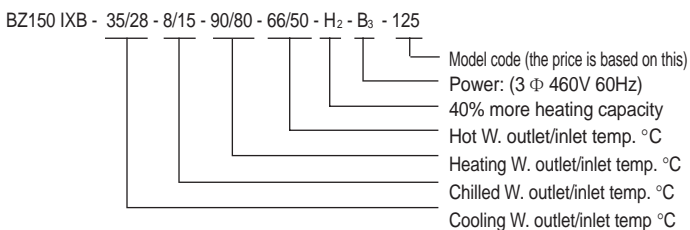

Example 3:(multi-energy DFA BZS type):

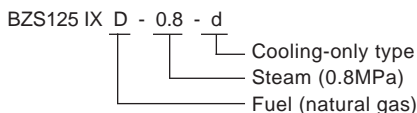

Example 4 (multi-energy DFA BZHE type):

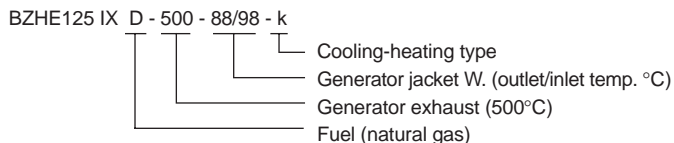

### 2. Two-stage Steam Chiller

Example 1 (standard)

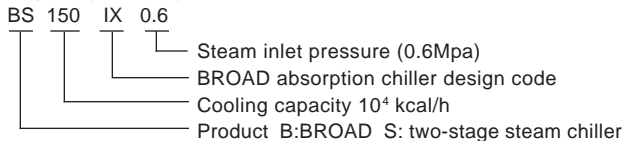

Example 2 (special)

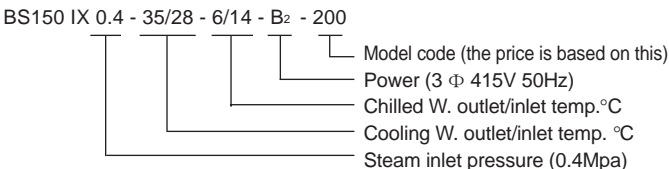

### 3. Single-steam Chiller

Example 1 (standard)

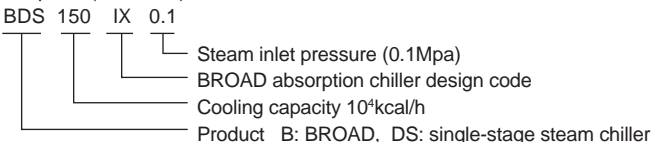

Example 2 (special)

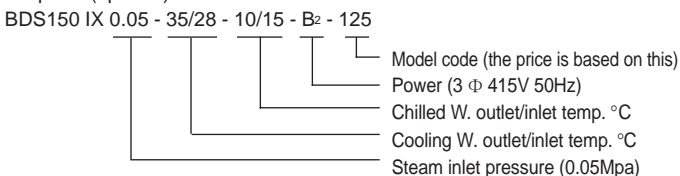

°C	°F
0	32.0
1	33.8
2	35.6
3	37.4
4	39.2
5	41.0
6	42.8
7	44.6
8	46.4
9	48.2
10	50.0
11	51.8
12	53.6
13	55.4
14	57.2
15	59.0
16	60.8
17	62.6
18	64.4
19	66.2
20	68.0
21	69.8
22	71.6
23	73.4
24	75.2
25	77.0
26	78.8
27	80.6
28	82.4
29	84.2
30	86.0
31	87.8
32	89.6
33	91.4
34	93.2
35	95.0
36	96.8
37	98.6
38	100.4
39	102.2
40	104
44	111
50	122
57	135
60	140
65	149
70	158
75	167
80	176
85	185
88	190
90	194
95	203
98	208
100	212
105	221
110	230
115	239
120	248
125	257
130	266
135	275
140	284
145	293
150	302
155	311
160	320
165	329
170	338
175	347
180	356
185	365
190	374
200	392
250	482
300	572
350	662
400	752
450	842
500	932
550	1022
600	1112

#### 4. Two-stage Hot Water Chiller

Example 1 (standard)

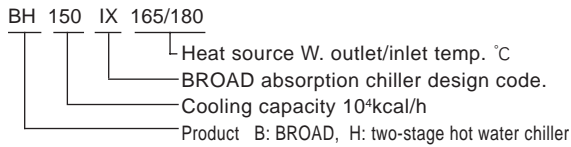

Example 2 (special):

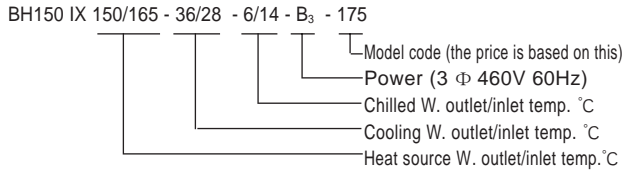

#### 5. Single-stage Hot Water Chiller

Example 1 (standard):

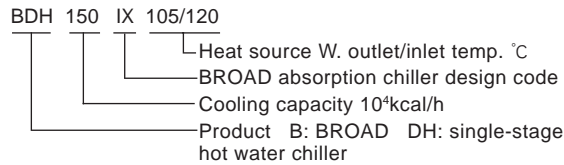

Example 2 (special):

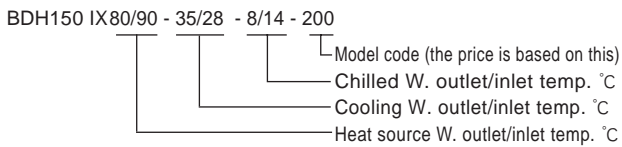

#### 6. Two-stage Exhaust Chiller/heater

Example 1 (standard):

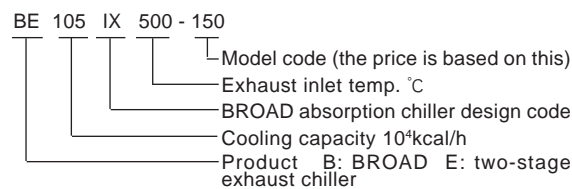

Example 2 (special):

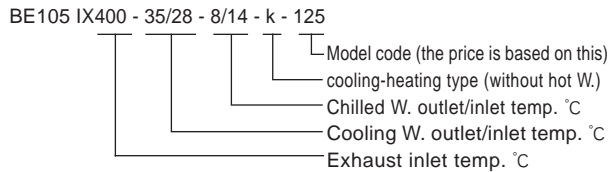

#### 7. Single-stage Exhaust Chiller/heater

Example 1 (standard):

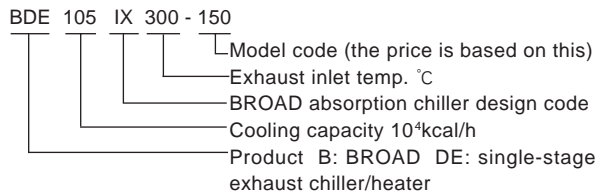

Example 2 (special):

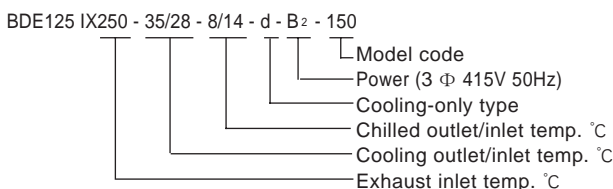

#### 8. Outdoor package

Example 1:

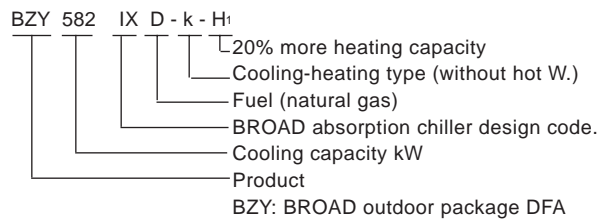

Example 3:

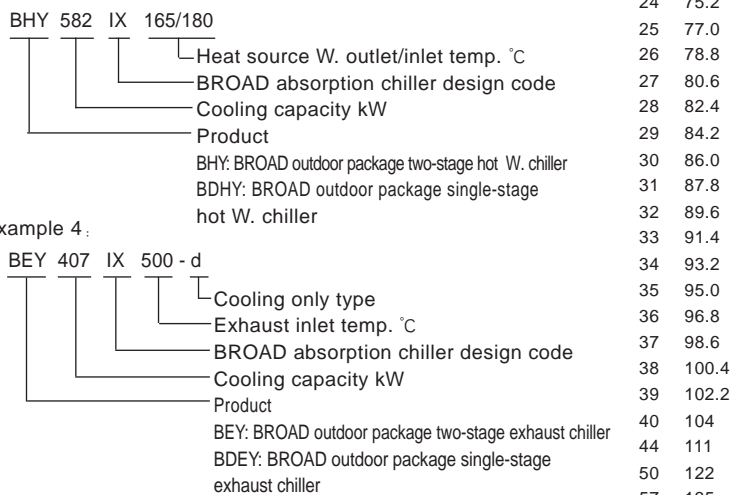

Example 4:

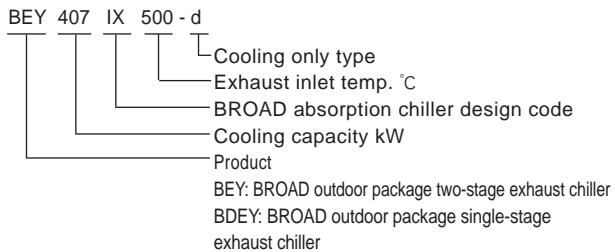

#### 9. BCT House Gas Air Con.

Example 1 (standard):

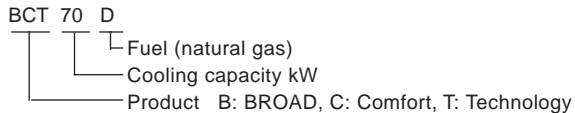

Example 2:

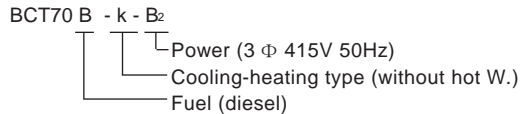

Example 3:

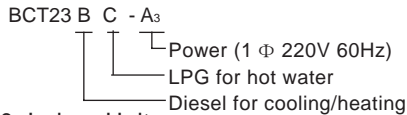

#### 10. Indoor Unit

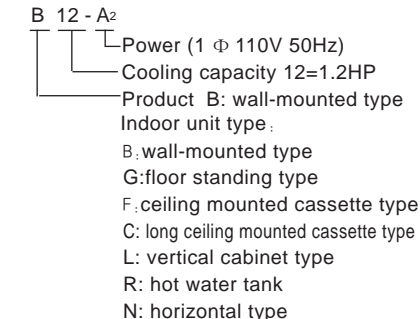

#### 11. Hot Water Tank

